

TIMES MICROWAVE SYSTEMS

TC-400-716MC (stock code: 3190-279)

Type 716 DIN-Male Plug

Solder-on center contact

Clamp-on outer contact

INSTALLATION INSTRUCTIONS

(Cable Types: LMR-400; 400 DB; 400 FR; 400 Ultraflex; 400 LLPL)

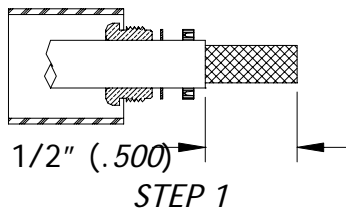
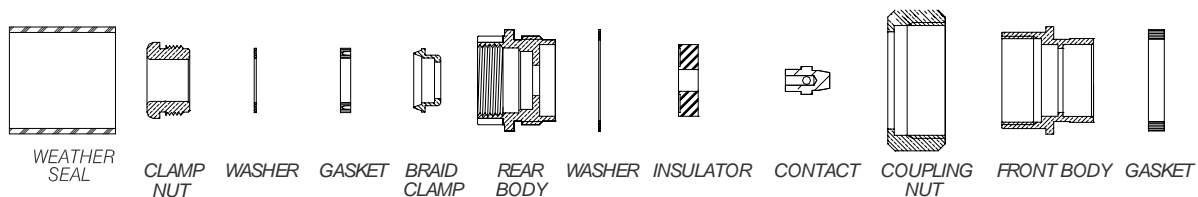

1. (A) Slide weather seal, clamp nut, washer and gasket onto cable. Cut jacket to dimensions shown. Be sure v-groove faces away from nut as shown.

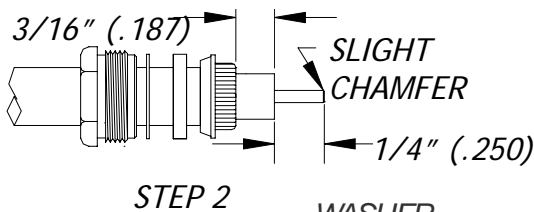

2. (A) Slide braid clamp over braid, being certain that clamp seats squarely against cut end of jacket.
(B) Form braid wires smoothly over clamp as shown and trim off excess wire even with shoulder.
(C) Cut conductor and dielectric to dimensions shown.
(D) Remove any residual plastic from center conductor.
(E) Deburr center conductor using a fine file or Times DBT-01 tool.

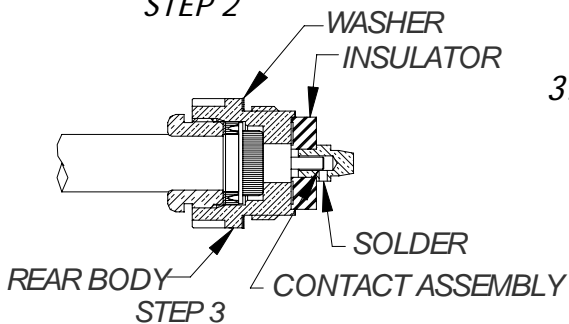

3. (A) Insert assembly into rear body, being certain that the braid clamp is seated. Tighten clamp nut to 60-65 lbs.-ins. torque with a wrench.
(B) Place insulator with flat side forward and contact on cable conductor. Seat firmly against body and soft solder to cable conductor. Use minimal heat to minimize melting of foam dielectric.

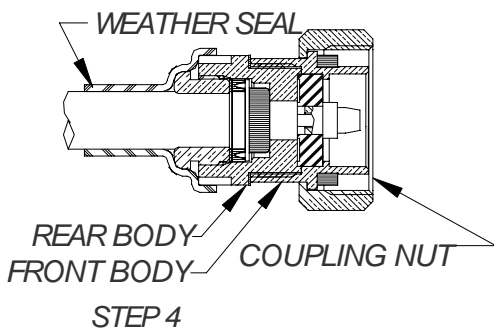

4. (A) Carefully insert rear body assembly into front body and tighten to 120-130 lbs.-ins. torque with a wrench.
(B) Heat shrink weather seal using hot air gun.

REV. C