

LTR	DESCRIPTION	DATE	BY
-	Released	11/7/96	JP
A	Redrawn	1/14/04	JCL

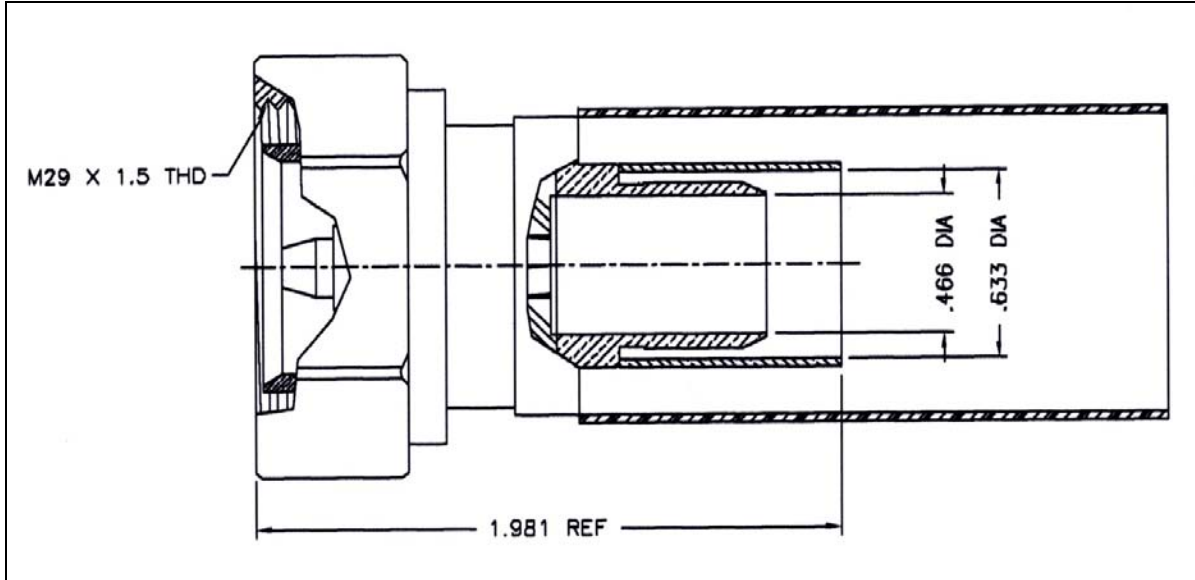

I. MATERIALS & FINISHES

- center contact: Silver Plated Brass
- outer contact: Silver Plated Brass
- coupling nut: Silver Plated Brass
- body: Silver Plated Brass
- crimp sleeve: Silver Plated Copper
- dielectric: Teflon® PTFE
- gasket: Silicone Rubber
- shrink sleeve: Adhesive Lined Polyolefin
- attachment: braid crimp (.610"hex)

II. ELECTRICAL PROPERTIES

- impedance: 50 ohms
- working voltage: 2700 vrms (max)
- vswr: 1.25:1 (max) up to 2.5 GHz
- insertion loss: 0.10 x √Fghz

Unless otherwise specified, dimensions are in inches. Tolerances are applicable when specified.

These drawings and specifications contain proprietary information which is the property of Times Microwave Systems.

Approvals		
Drawn	JCL	11/7/96



TIMES MICROWAVE SYSTEMS
 Wallingford, CT 06492
 (203) 949-8400; (203) 949-8423.Fax
 www.timesmicrowave.com

EZ-600-716MH
 Type-716 DIN male (plug) – Non-Solder Pin
 for LMR-600 Cable

Size A	CAGE CODE 68999	Drawing No.: 3190-503
Scale: NA	Rev. (A)	Sheet: 1 of 1