

LTR	DESCRIPTION	DATE	BY
-	Released	3/25/96	JCL
A	Redrawn and Updated	7/8/04	JCL

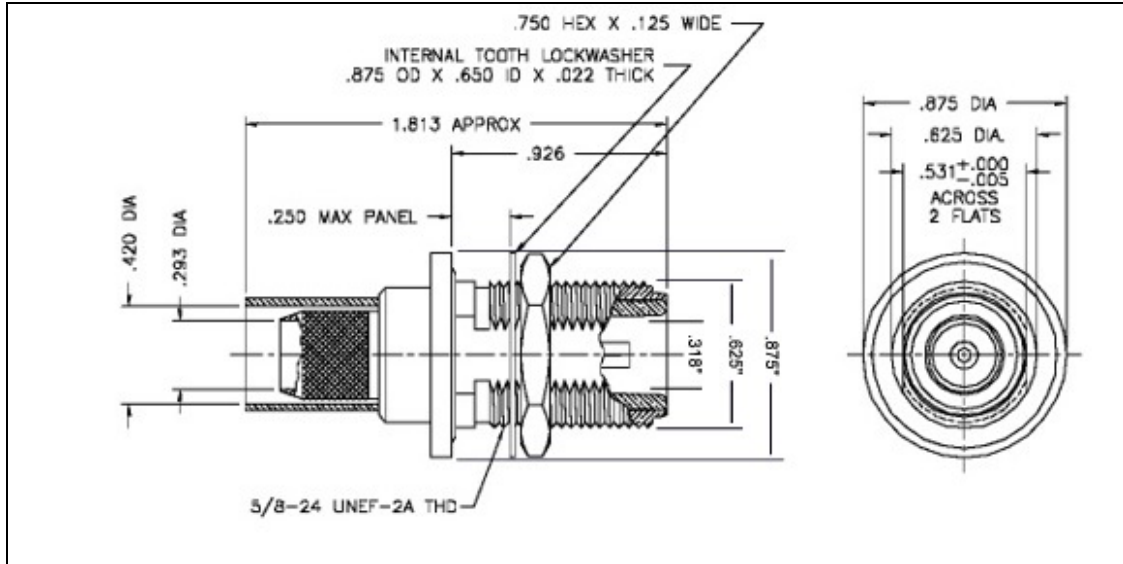

I. MATERIALS & FINISHES

- center contact: Gold Plated Beryllium Copper
- outer contact: Nickel Plated Brass
- body: Nickel Plated Brass
- crimp sleeve: Nickel Plated Copper
- dielectric: Teflon® PTFE
- gasket: Silicone Rubber
- shrink sleeve: Adhesive Lined Polyolefin
- attachment: braid crimp .429" hex

II. ELECTRICAL PROPERTIES

- impedance: 50 ohms
- working voltage: 1000 vrms (max)
- vswr: 1.25:1 (max) up to 2 GHz
- insertion loss: 0.15 x √Fghz

Unless otherwise specified, dimensions are in inches. Tolerances are applicable when specified.

These drawings and specifications contain proprietary information which is the property of Times Microwave Systems.

Approvals		
Drawn	JCL	3/25/96

TIMES MICROWAVE SYSTEMS
 Wallingford, CT 06492
 (203) 949-8400; (203) 949-8423.Fax
 www.timesmicrowave.com

EZ-400-NF-BH
 Type-N female Bulkhead
 for LMR-400 Cable

Size A	CAGE CODE 68999	Drawing No.: 3190-518
-----------	---------------------------	---------------------------------

Scale: NA	Rev. (A)	Sheet: 1 of 1
-----------	----------	---------------