

NOTICE OF PROPRIETARY RIGHTS THIS DOCUMENT CONTAINS CONFIDENTIAL TECHNICAL DATA, INCLUDING TRADE SECRETS, PROPRIETARY TO TIMES MICROWAVE SYSTEMS. DISCLOSURE OF THIS DATA IS EXPRESSLY CONDITIONED UPON YOUR ASSENT THAT ITS USE IS LIMITED TO USE WITHIN YOUR COMPANY ONLY. ANY OTHER USE IS STRICTLY PROHIBITED WITHOUT THE PRIOR WRITTEN CONSENT OF TIMES MICROWAVE SYSTEMS.

SYM	REVISION DESCRIPTION	DFTM	DATE	APPD	DATE
-	RELEASED FOR PRODUCTION	J. C. L.	5/2/03	J. C. L.	5/2/03
B	Updated Sketch; Knurl to Hex Nut	J. C. L.	6/30/03	J. C. L.	6/30/03
C	CHANGED PER CDC #30590	D. J. H.	9/1/09	J. D. B.	9/1/09

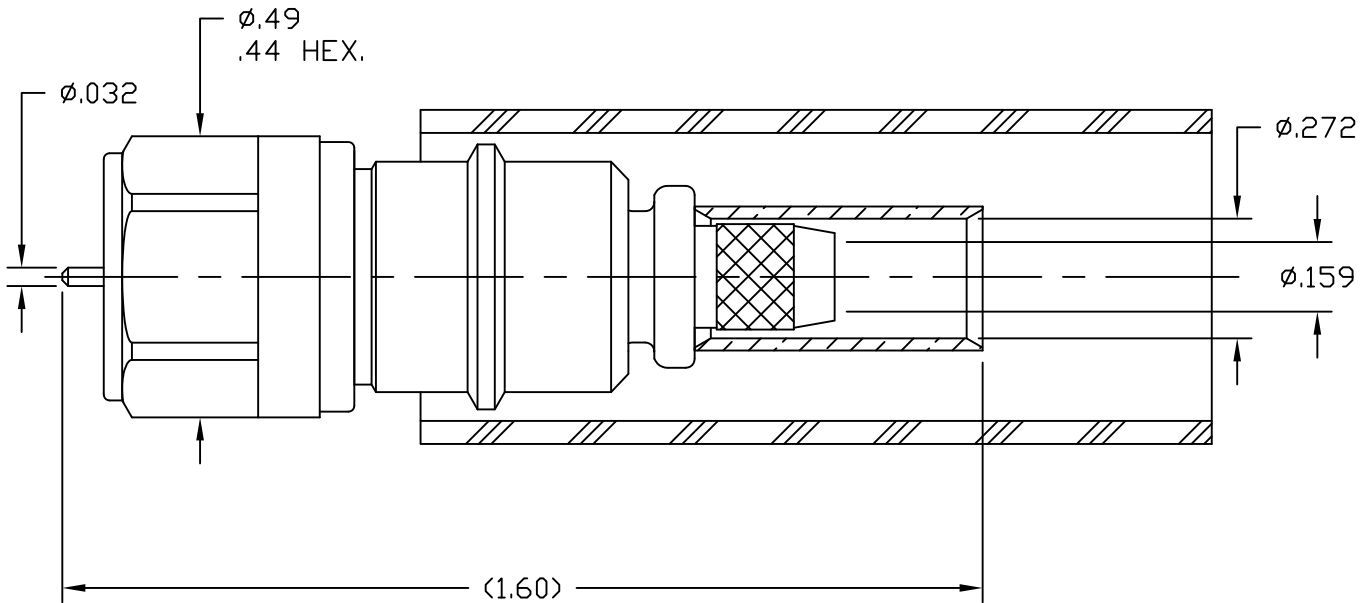

BODY	CONTACT
NICKEL	50 GOLD/Cu

- | | |
|--|--|
| 1.0 PERFORMANCE | 2.3 CRIMP FERRULE: DHP SOFT COPPER, CDA 122, SOFT TEMPER |
| 1.1 FREQUENCY RANGE: DC-2 GHz | 2.4 LOCKING RING: PHOSPHOR BRONZE, ASTM-B-159 |
| 1.2 NOMINAL IMPEDANCE: 75 OHMS | 2.5 OTHER METAL PARTS: BRASS PER ASTM-B-16 |
| 1.3 DWV: 1000 V RMS @ 60 Hz (sea level) | 2.6 GASKET: SILICON RUBBER, ZZ-R-765, GR. 50, RED |
| 1.4 TEMPERATURE RANGE: -65°C TO +165°C | 2.7 SHRINK SLEEVE: THICK WALL POLYOLEFIN, MIL-I-23053/4, CLASS 3 |
| 2.0 MATERIALS | 3.0 FINISHES: SEE TABLE |
| 2.1 DIELECTRIC: PTFE, ASTM-D-1710 | 4.0 MECHANICAL |
| 2.2 CENTER CONTACT: BERYLLIUM COPPER, ASTM-B-196 | 4.1 INTERFACE: IN ACCORDANCE WITH: EIA STANDARD 550 |

MATERIAL:	UNLESS OTHERWISE SPECIFIED ALL DIMENSIONS ARE IN INCHES MACHINED SURFACES FINISH N/A RMS MAX. REMOVE ALL BURRS .005 MAX. BREAK MACHINE CORNERS .005 MAX. FILLET R. TOLERANCES ON DECIMALS .XX ± .03 .XXX ± .005 ANGLES ± 1° FRACTIONS ± 1/32	DFTM. J. C. L.	TIMES MICROWAVE SYSTEMS
		DATE 5/2/03	
USED ON: E		CHKD. J. C. L.	TC-240-FMH-75 TYPE F MALE, STRAIGHT PLUG FOR LMR-240-75 CABLE
		DATE 5/2/03	
SCALE: N/A	DWG. SIZE A	APPD. J. C. L.	SHEET 1 of 1
		DATE 5/2/03	
DO NOT SCALE DRAWING	CODE IDENT 68999	DATE 5/2/03	REV C