

TIMES MICROWAVE SYSTEMS

INSTALLATION INSTRUCTIONS SC-400-NM (3190-1454) (Cable Types: LMR-400)

358 Hall Avenue/P.O. Box 5039
Wallingford, CT 06492-5039
Tel: 203-949-8400
FAX: 203-949-8423
1-800-TMS-COAX
www.timesmicrowave.com

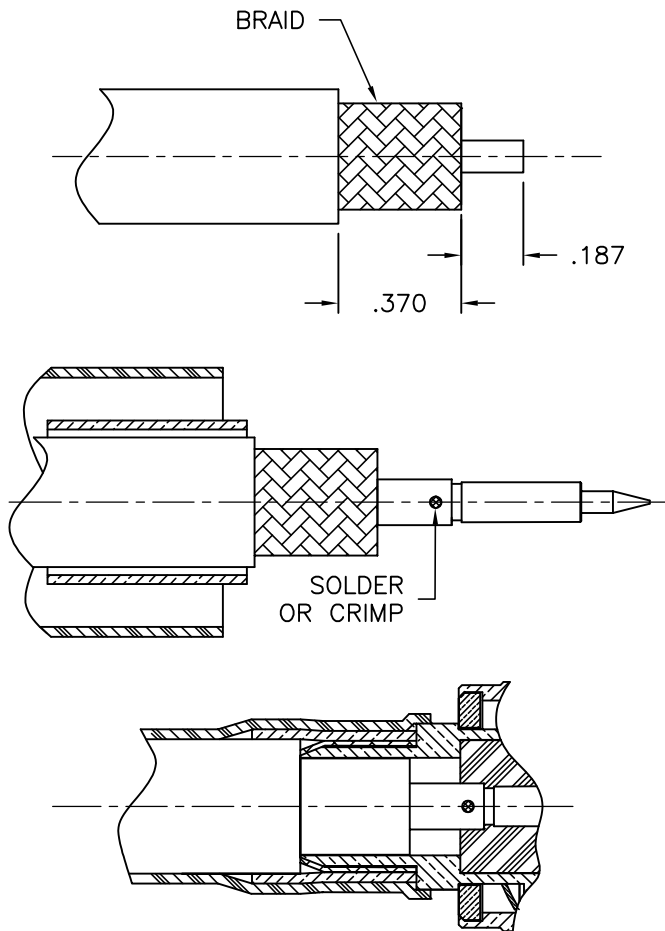
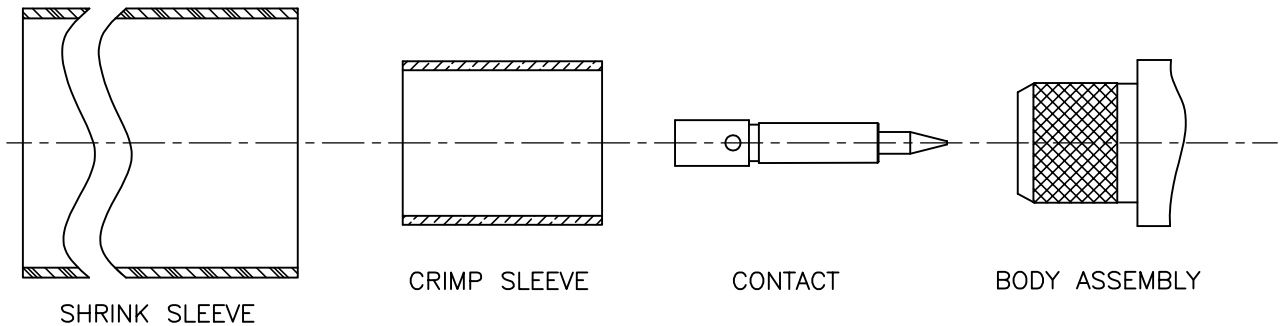

1. A. Trim cable per dimensions shown.
B. Remove any residual plastic from the center conductor and deburr center conductor using a fine file.
2. A. Solder contact to center conductor of cable as shown or crimp using tool M22520/1-01 with positioner M22520/1-13, green turret, tool selector 8. Use minimal heat to minimize melting of foam dielectric. Inspect to be sure aluminum foil is not touching center contact.
B. Slide crimp sleeve & shrink sleeve over cable.
3. A. Insert cable into connector until contact shoulder is flush with insulator, with all braided wires on the outside of the connector body and aluminum tape inside connector body.
B. Slide crimp sleeve forward and crimp as close as possible to body using a .429" hex die. Use Times HX-4 crimp tool or equivalent. Do not crimp rear of crimp sleeve.
C. Slide shrink sleeve into place and heat shrink over rear of body with hot air gun.