

**TIMES** MICROWAVE SYSTEMS

## EZ-200-FMH-75 (stock code: 3190-1611) Type F PLUG

Non-solder center contact  
Crimp-on (.213" hex. die) outer contact

### INSTALLATION INSTRUCTIONS

(Cable Types: LMR-200-75)

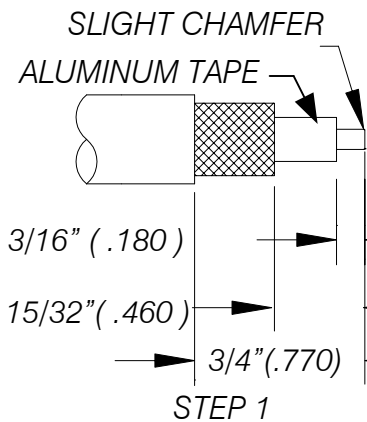

1. (A) Trim cable to dimensions shown.  
(B) Remove any metal debris or residual plastic from center conductor and/or dielectric.  
(C) Deburr center conductor using a fine file or Times Deburring Tool.  
(D) Avoid nicking aluminum tape or center conductor.

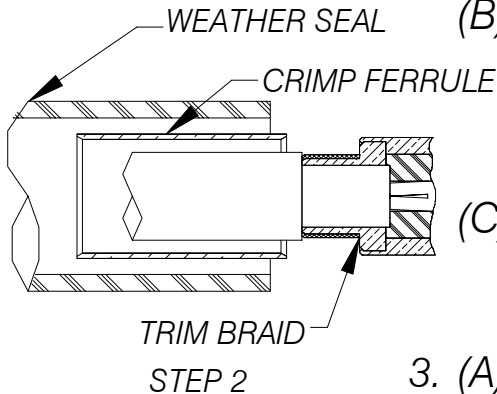

2. (A) Slide weather seal and crimp ferrule over cable.  
(B) Flare braid and insert cable into connector body until dielectric is seated with all braid wires on outside of connector body and aluminum tape inside connector body.  
(C) Braid should assemble flush to within 1/16" (.06) of connector shoulder. Trim braid as necessary.

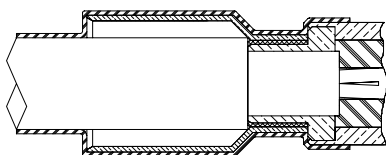

3. (A) Slide crimp ferrule over braid and crimp as close to connector body as possible using hex dies indicated (above) in a Times HX-4 crimp tool or equivalent. Do not crimp rear of crimp ferrule.  
(B) Heat shrink weather seal over rear of connector body and down on to cable jacket using hot air gun.

STEP 3

REV-A