

SYM	REVISION DESCRIPTION	DFTM	DATE	APPD	APPD
A	RELEASED FOR PRODUCTION	Patrick	2019/03/30	Joslen	2019/03/30

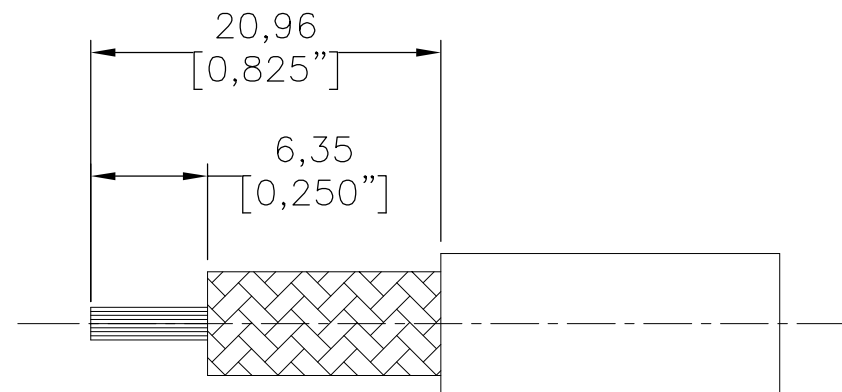
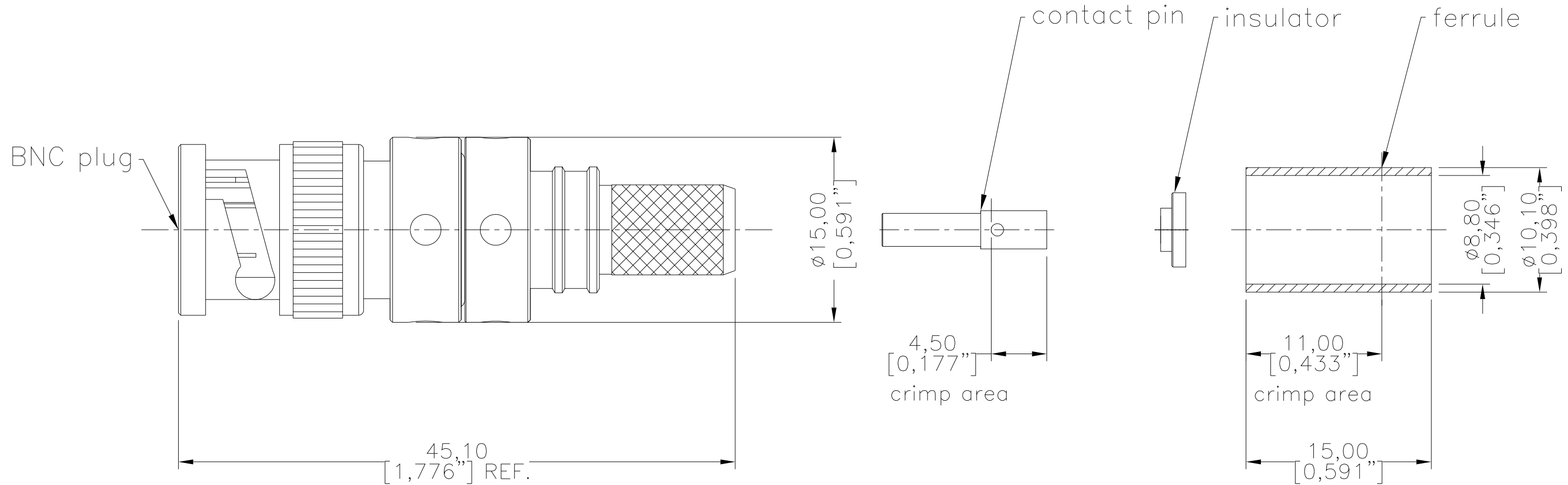

RECOMMENDED CABLE STRIPPING DIM'S  
Connector Adds: 28.7 mm

**I. MATERIALS & FINISHES**

Components	Materials	Finishes	Thk. (μ")
Body	Brass	Sn-Ni	100
Contact Pin	Beryllium Copper	Gold	50
Insulator	PTFE	--	--
Shell	Brass	Sn-Ni	100
Ferrule	Brass	Sn-Ni	100
Gasket	Silicone Rubber	--	--

**II. ELECTRICAL PROPERTIES**

Impedance (Ω):	50
Frequency Range (GHz):	DC-4
Dielectric Withstanding Voltage (V):	1500
Insulation Resistance (MΩ):	≥5000
VSWR: for solder center contact	≤1.30
for crimp center contact	≤1.35
Insertion Loss(dB, f in GHz):	-0.1x√f

**III. ENVIRONMENT PROPERTIES**

Temperature Range:	-65°C~+165°C
Thermal Shock:	MIL-STD 202G, Meth.107, Cond. B
Vibration:	MIL-STD 202G, Meth.204, Cond. B
Shock:	MIL-STD 202G, Meth.213, Cond. I
Climatic Class:	IEC 60068 55/155/21
RoHS:	Compliant

**IV. MECHANICAL PROPERTIES**

Center Contact:	Solder/Crimp
Outer Contact:	Crimp
Coupling Nut Torque (in.lbs):	0.6-2.5
Cbl-Connector Retention Force (lbs):	100
Durability (Cycles):	500

**V. TOOLING**

Stripping Tool:	N/A
Crimping Size	
Center Contact:	.100" HEX.
Outer Contact:	.359" HEX.
Heat Shrink Tube:	1/2"x1.5" (3:1) 1 pcs

Interface Compatible with Standard:  
IEC 61169-8  
MIL-STD-348

MATL:	UNLESS OTHERWISE SPECIFIED	DFTM. Patrick	<p><b>TC-3112-BM-X</b> BNC Male (Plug) Straight Solder/Crimp Pin No Braid Trim Connector for TCA311201 Cable</p>				
	ALL DIMENSIONS ARE IN mm MACHINED SURFACES FINISH 1.6 RMS MAX. REMOVE ALL BURRS 0.15X45° MAX. BREAK MACHINE CORNERS 0.15X45° D MAX. FILLET R. TOLERANCES ON DECIMALS .X ±0.3 .XX ±0.15 ANGLES ±2° FRACTIONS ± N/A	DATE 2019/03/30					
		CHKD Monica					
		DATE 2019/03/30					
USED ON: O		APPD Joslen					
SCALE: N/A	DWG SIZE A3	DO NOT SCALE DRAWING	CODE INFNT 68999	DATE 2019/03/30	SHT 1/1	<b>3190-8083</b>	REV A