

8 7 6 5 4 3 2 1
 NOTICE OF PROPRIETARY RIGHTS: THIS DOCUMENT CONTAINS CONFIDENTIAL DATA, INCLUDING TRADE SECRETS, PROPRIETARY TO TIMES MICROWAVE SYSTEMS. DISCLOSURE OF THIS DATA IS EXPRESSLY CONDITIONED UPON YOUR ASSENT THAT ITS USE IS LIMITED TO USE WITHIN YOUR COMPANY ONLY. ANY OTHER USE IS STRICTLY PROHIBITED WITHOUT THE PRIOR WRITTEN CONSENT OF TIMES MICROWAVE SYSTEMS.

VER	Description	ECN	Name	Date
A	Initial Released	N/A	Patrick	2018/10/20

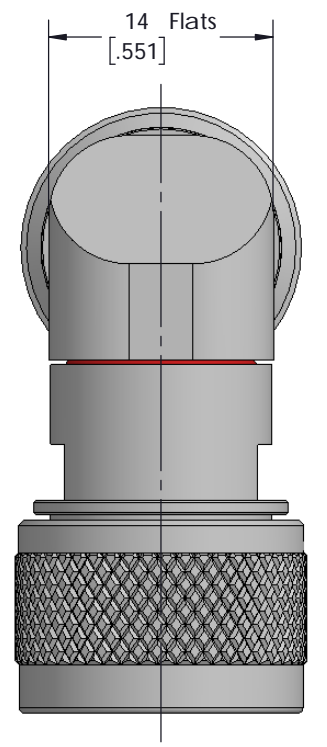
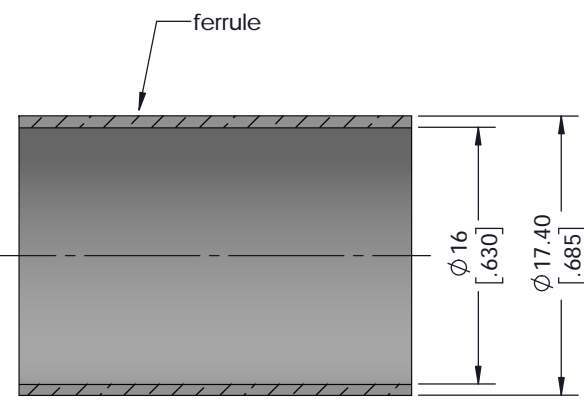
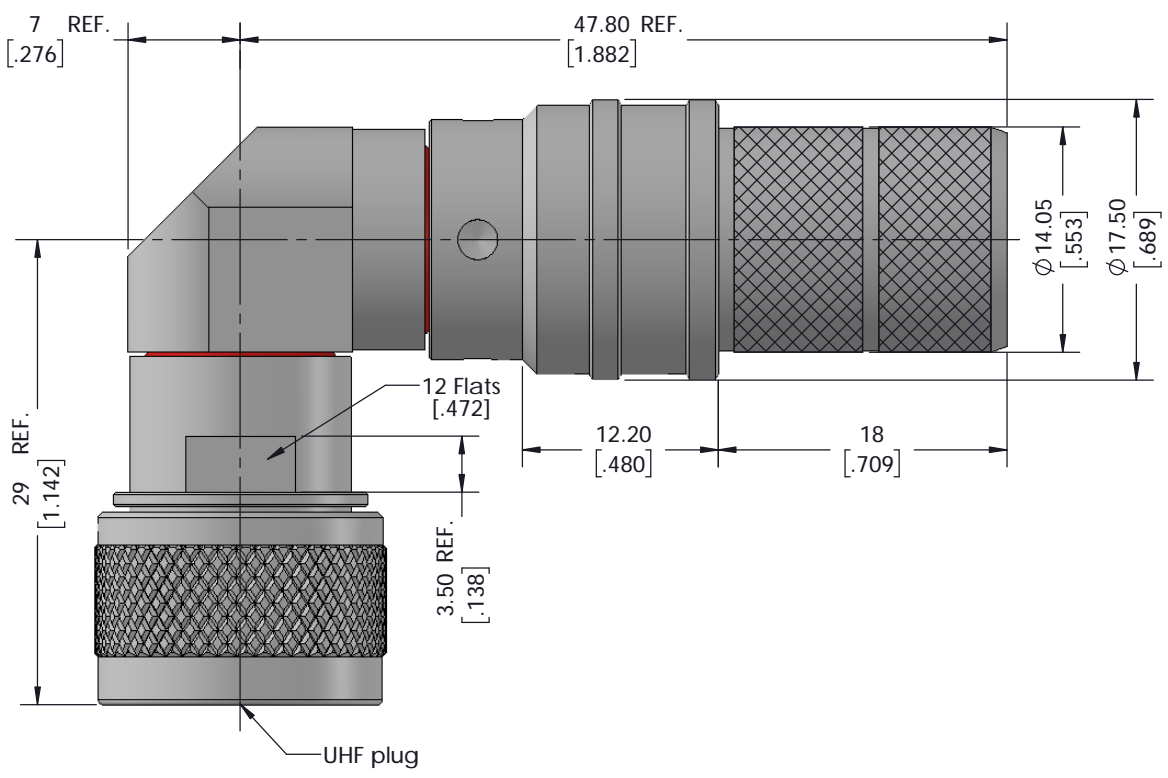

I. MATERIALS & FINISHES

Component	Material	Finishes	Thk. (u")
Body	Brass	Sn-Ni	100
Contact Pin	Phosphor Bronze	Silver	200
Insulator	PTFE	--	--
Coupling Nut	Brass	Sn-Ni	100
Ferrule	Copper	Sn-Ni	100

II. ELECTRICAL PROPERTIES

Impedance (Ω):	50
Frequency Range (GHz):	DC~3 GHz
Dielectric Withstanding Voltage (V r.m.s):	2000
Insulation Resistance (MΩ):	≥10000
VSWR:	≤1.30 (DC~2.45 GHz)
Insertion Loss (dB, f / GHz):	-0.1 x sqrt (f)

III. ENVIRONMENT PROPERTIES

Temperature Range:	-40°C~+125°C
Thermal Shock:	MIL-STD-202, Meth. 107, Cond. B
Vibration:	MIL-STD-202, Meth. 204, Cond. B
Shock:	MIL-STD-202, Meth. 213, Cond. G
Climatic Class:	IEC 60068 55/155/21
RoHS:	Compliant

IV. MECHANICAL PROPERTIES

Center Conductor:	Spring Finger
Outer Conductor:	Crimp
Coupling Nut Torque (in-lbs):	N/A
Cable-Connector Retention Force (lbs):	200
Durability (Cycles):	500

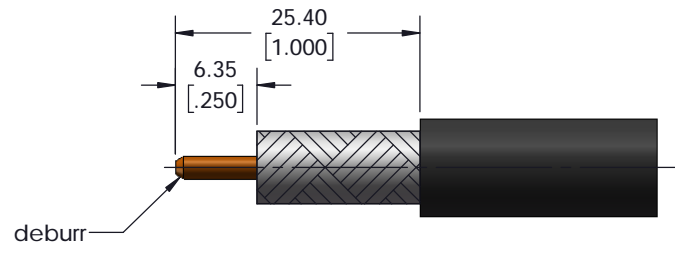

RECOMMENDED CABLE STRIPPING DIM'S
 Connector Adds: 24.75 mm

Compatible with Standard: IEC 60169-12

- V. Tooling & Accessories**
- Stripping Tool: 3192-052/CST-600
 - Crimping Tool: 3192-170/CT-600
 - Heat Shrink Tube: 1"x2" (3:1) 1 pcs

UNLESS OTHERWISE SPECIFIED				DFTM	Patrick							
ALL DIMENSIONS ARE IN mm MACHINED SURFACES FINISH 1.6 RMS MAX. REMOVE ALL BURRS 0.15X45° MAX. BREAK MACHINE CORNERS 0.15X45° D MAX. FILLET R. TOLERANCES ON DECIMALS .X ±0.1 .XX ±0.15 ANGLES ±2° FRACTIONS ±N/A				DATE	2018/10/20							
				CHKD	Monica							
				DATE	2018/10/20							
				APPD	Joslen							
Scale:	3:1	Size:	A3	CODE IDENT	68999	DATE	2018/10/20	SHT	1/1	3190-8037	REV	A

EZ-600-UM-RA-X
 UHF Male (Plug) Right Angle Non-Solder Pin No Braid Trim Connector for LMR-600 Cable