

NOTICE OF PROPRIETARY RIGHTS THIS DOCUMENT CONTAINS CONFIDENTIAL DATA, INCLUDING TRADE SECRETS, PROPRIETARY TO TIMES MICROWAVE SYSTEMS. DISCLOSURE OF THIS DATA IS EXPRESSLY CONDITIONED UPON YOUR ASSENT THAT ITS USE IS LIMITED TO USE WITHIN YOUR COMPANY ONLY. ANY OTHER USE IS STRICTLY PROHIBITED WITHOUT THE PRIOR WRITTEN CONSENT OF TIMES MICROWAVE SYSTEMS.

SYM	REVISION DESCRIPTION	DFTM	DATE	APPD	DATE
A	RELEASED FOR PRODUCTION	JW	08/08/2014	TZ	08/08/2014

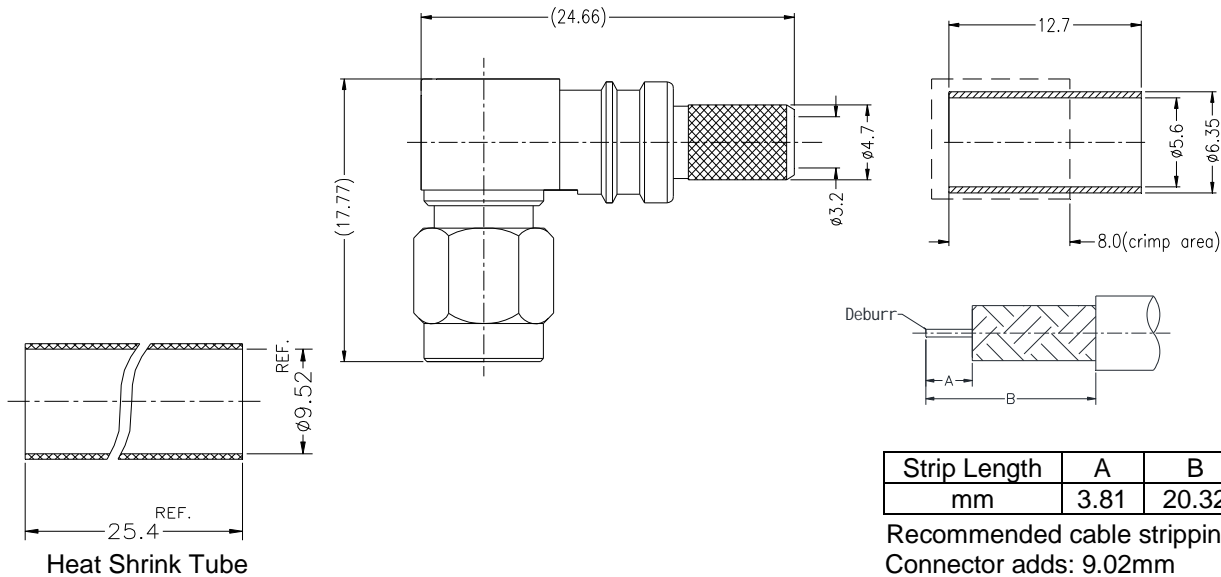

I. MATERIALS & FINISHES

Components	Materials	Finishes	Thk. (μ'')
Body	STAINLESS STEEL	PASSIVATION	--
Center Cont.	BeCu	Gold	50
Insulator	TEFLON	--	--
Gasket	Silicone	Red	--
Ferrule	Brass	Albaloy	80
Coupling nut	STAINLESS STEEL	PASSIVATION	--

II. ELECTRICAL PROPERTIES

Impedance (Ω):	50
Frequency Range (GHz):	DC to 6.0
Working Voltage (V):	500
Insulation Resistance (MΩ):	≥5000
VSWR:	1.35:1
Insertion Loss:	0.05 x sqrt(f)

III. ENVIRONMENT PROPERTIES

Temperature Range:	-55°C~+125°C
Thermal Shock:	MIL-STD 202G, Meth.107, Cond.B
Vibration:	MIL-STD 202G, Meth.204, Cond.B
Shock:	MIL-STD 202G, Meth.213, Cond I
Climatic Class:	IEC 60068 55/155/56
(2002/95/EC)RoHS:	Compliant

IV. MECHANICAL PROPERTIES

Center Cont.:	Captive
Outer Cont.:	Crimp
Coupling Nut Torque (N.m):	0.8-1.1
Cbl-Connector Retention Force (N):	230
Durability (cycles):	≥500

V. TOOLING

Stripping Tool:	3192-102/CST-195/200
Crimping Tool:	3190-667

MATL:		UNLESS OTHERWISE SPECIFIED			DFTM. JW		TIMES MICROWAVE SYSTEMS EZ-200-SM-RA-SS-X SMA Male(Plug) Right Angle No Braid Trim Connector for LMR-200 Cable Type(s)					
USED ON: O		ALL DIMENSIONS ARE IN mm MACHINED SURFACES FINISH 1.6 RMS MAX. REMOVE ALL BURRS 0.15X45° MAX. BREAK MACHINE CORNERS 0.15X45° D MAX. FILLET R. TOLERANCES ON DECIMALS .X ±0.3 .XX ±0.15 ANGLES ±2° FRACTIONS ±N/A			DATE 14/08/08							
					CHKD. KG							
					DATE 14/08/08							
SCALE: N/A		DO NOT SCALE DRAWING			APPD. TZ		SHT 1 of 1		3190-6006		REV A	