

NOTICE OF PROPRIETARY RIGHTS THIS DOCUMENT CONTAINS CONFIDENTIAL TECHNICAL DATA, INCLUDING TRADE SECRETS, PROPRIETARY TO TIMES MICROWAVE SYSTEMS. DISCLOSURE OF THIS DATA IS EXPRESSLY CONDITIONED UPON YOUR ASSENT THAT ITS USE IS LIMITED TO USE WITHIN YOUR COMPANY ONLY. ANY OTHER USE IS STRICTLY PROHIBITED WITHOUT THE PRIOR WRITTEN CONSENT OF TIMES MICROWAVE SYSTEMS.

SYM	REVISION DESCRIPTION	DFTM	DATE	APPD	DATE
A	RELEASED FOR PRODUCTION	N.N.N	9/4/13	J.D.B.	9/10/13

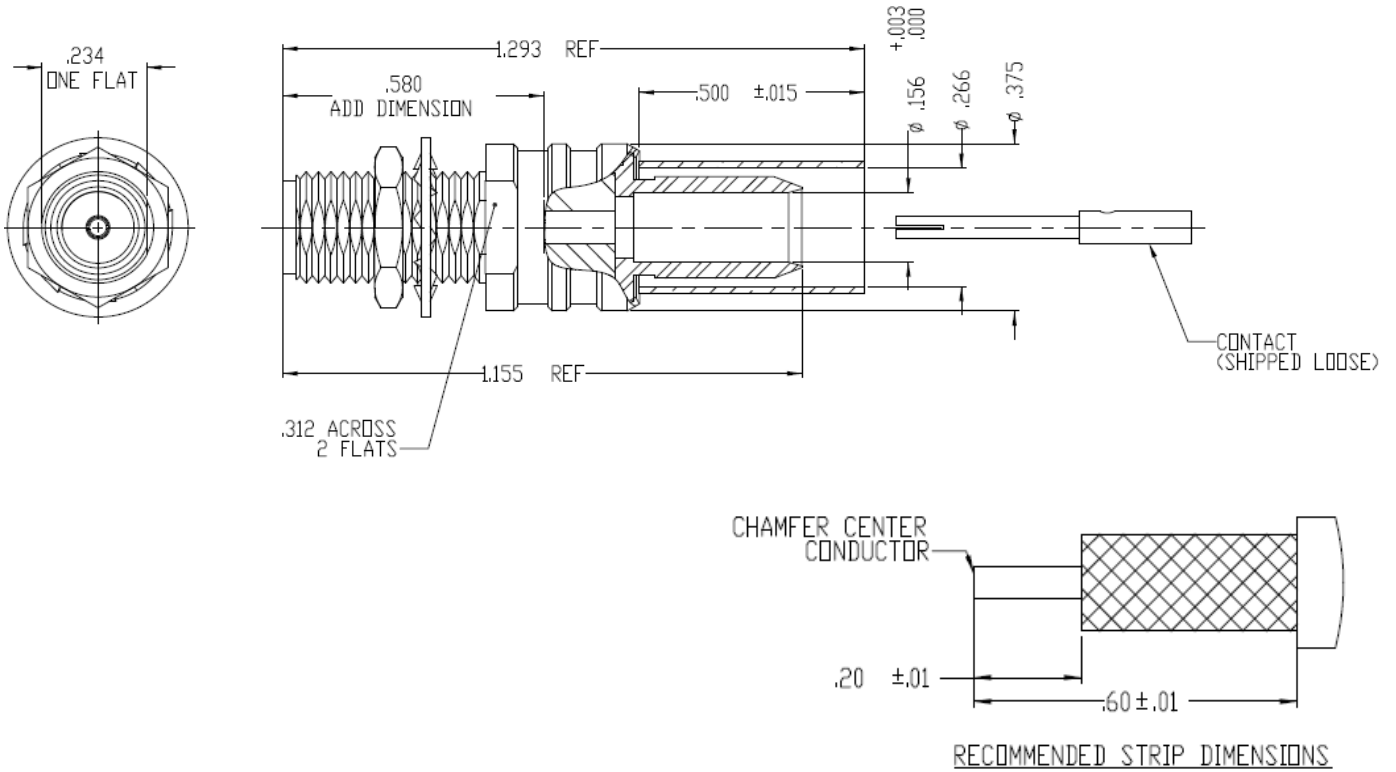

NOTES:

- ASSEMBLED CONNECTOR INTERFACE IS DESIGNED IN ACCORDANCE WITH MIL-STD-348.
- MATERIAL:**
 BODY, HEX NUT, LOCKWASHER, TAIL - STAINLESS STEEL PER ASTM 582, S30300 ALLOY, COND. A
 INSULATOR - TEFLON PER ASTM D1710, TYPE 1, GRADE 1, CLASS A
 CONTACT - BERYLLIUM COPPER PER ASTM B196, C17300 ALLOY, CONDITION HT
 SHRINK SLEEVE - HEAT SHRINKABLE ATUM PER MIL-I-23053/4 (NOT SHOWN)
 CRIMP SLEEVE - D.H.P. COPPER CDA, ALLOY #122, TEMPER HARD
- FINISH:**
 CONTACT - GOLD PLATE PER ASTM B488
 CRIMP SLEEVE - SULFAMATE NICKEL PER MIL-P-27418
 ALL OTHER METAL PARTS - PASSIVATE PER SAE-AMS-2700

MATERIAL:	UNLESS OTHERWISE SPECIFIED ALL DIMENSIONS ARE IN INCHES MACHINED SURFACES FINISH 63 RMS MAX. REMOVE ALL BURRS .004 MAX. BREAK MACHINE CORNERS .005 MAX. FILLET R. TOLERANCES ON DECIMALS .XX ± .01 .XXX ± .005 ANGLES ± 1° FRACTIONS ± 1/64	DFTM. N. N. N	TIMES MICROWAVE SYSTEMS		
		DATE 9/4/13	TC-240-SF-BH-SS-X		
USED ON: B		CHKD. J. D. B.	CONNECTOR ASSEMBLY		
		DATE 9/10/13	SMAF Bulkhead for LMR-240		
SCALE: NONE	DWG. SIZE A	APPD. J. D. B.	SHEET 1 of 1	SD3190-2896	REV A
		DO NOT SCALE DRAWING			
	CODE IDENT 68999				