

Connector Comparison Sheet

	Old Connector 3190-552 TC-400-NMH-D	New Connector 3190-2626 TC-400-NMH-X																																								
1. Materials&Plating	<table border="1"> <thead> <tr> <th></th> <th>Material</th> <th>Plating</th> <th>Thickness</th> </tr> </thead> <tbody> <tr> <td>1) Body</td> <td>Brass</td> <td>Albaloy</td> <td></td> </tr> <tr> <td>2) Center Contact</td> <td>Brass</td> <td>Gold</td> <td></td> </tr> <tr> <td>3) Coupling nut</td> <td>Brass</td> <td>Albaloy</td> <td></td> </tr> <tr> <td>4) Ferruel</td> <td>Copper</td> <td>Albaloy</td> <td></td> </tr> </tbody> </table>		Material	Plating	Thickness	1) Body	Brass	Albaloy		2) Center Contact	Brass	Gold		3) Coupling nut	Brass	Albaloy		4) Ferruel	Copper	Albaloy		<table border="1"> <thead> <tr> <th></th> <th>Material</th> <th>Plating</th> <th>Thickness</th> </tr> </thead> <tbody> <tr> <td>1) Body</td> <td>Brass</td> <td>Albaloy</td> <td>>79μ"(2μm)</td> </tr> <tr> <td>2) Center Contact</td> <td>Brass</td> <td>Gold</td> <td>>50μ"(1.27μm)</td> </tr> <tr> <td>3) Coupling nut</td> <td>Brass</td> <td>Albaloy</td> <td>>79μ"(2μm)</td> </tr> <tr> <td>4) Ferruel</td> <td>Copper</td> <td>Albaloy</td> <td>>79μ"(2μm)</td> </tr> </tbody> </table>		Material	Plating	Thickness	1) Body	Brass	Albaloy	>79μ"(2μm)	2) Center Contact	Brass	Gold	>50μ"(1.27μm)	3) Coupling nut	Brass	Albaloy	>79μ"(2μm)	4) Ferruel	Copper	Albaloy	>79μ"(2μm)
	Material	Plating	Thickness																																							
1) Body	Brass	Albaloy																																								
2) Center Contact	Brass	Gold																																								
3) Coupling nut	Brass	Albaloy																																								
4) Ferruel	Copper	Albaloy																																								
	Material	Plating	Thickness																																							
1) Body	Brass	Albaloy	>79μ"(2μm)																																							
2) Center Contact	Brass	Gold	>50μ"(1.27μm)																																							
3) Coupling nut	Brass	Albaloy	>79μ"(2μm)																																							
4) Ferruel	Copper	Albaloy	>79μ"(2μm)																																							
2. Dimension&Outline																																										
3. Installation	Need Braid Trim	No Braid Trim																																								

4. Test Curve

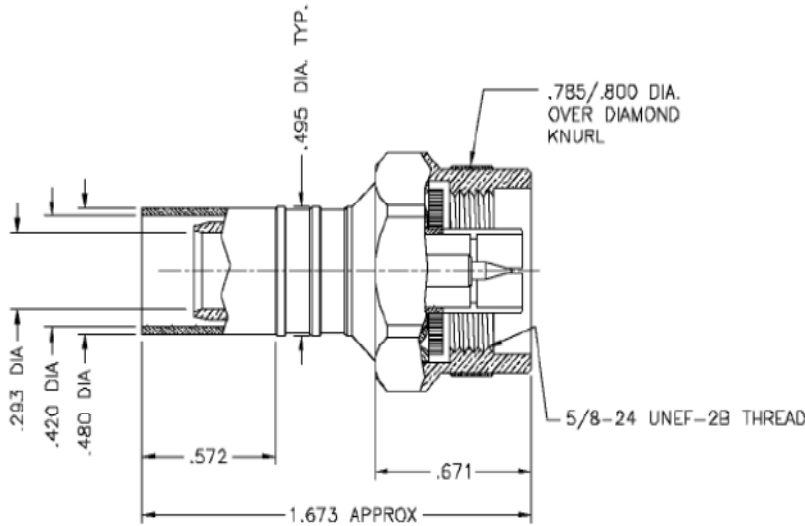
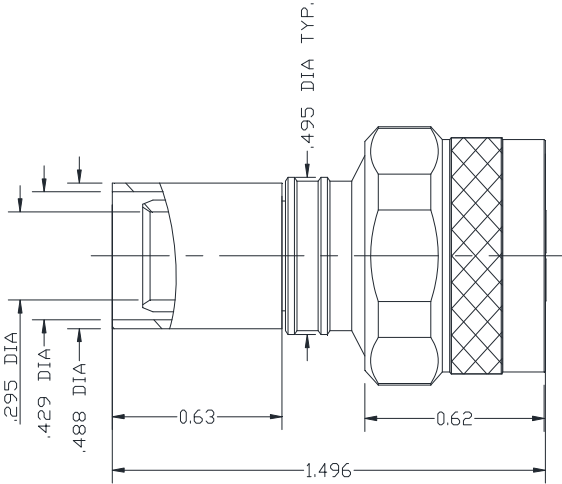
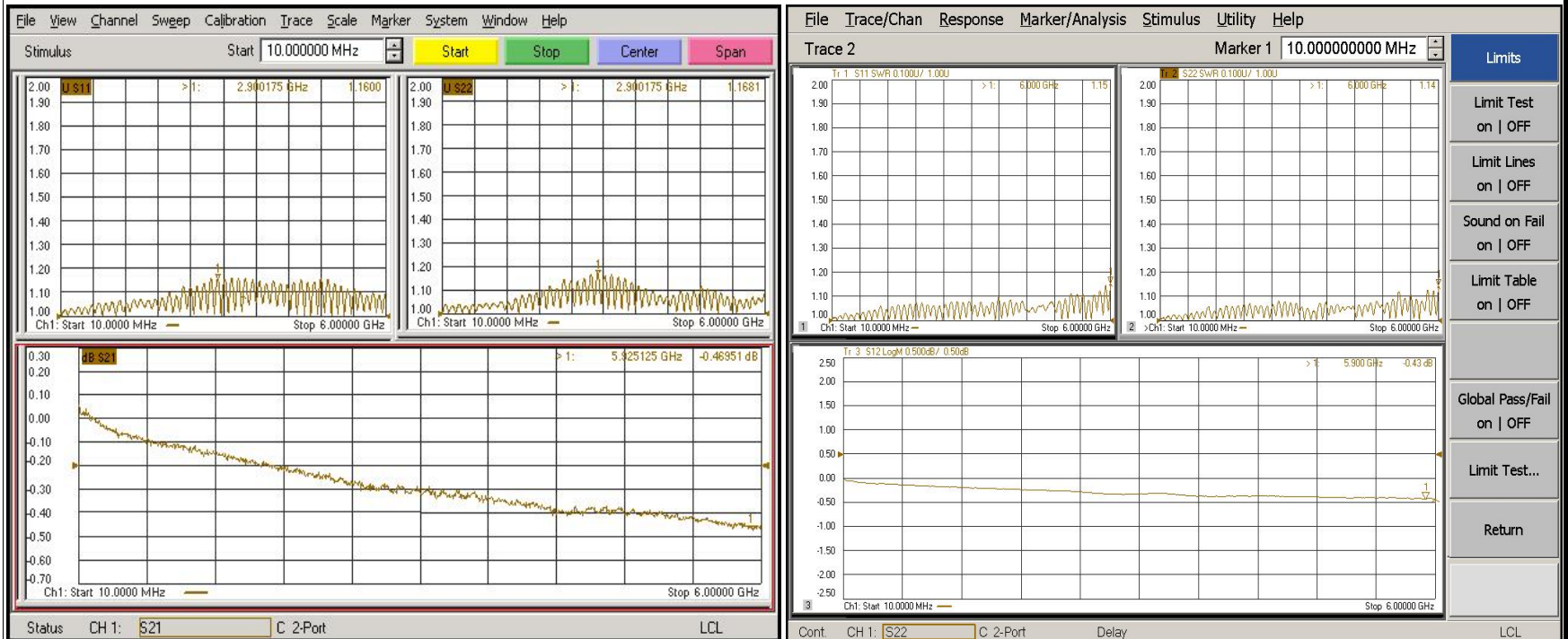

* The test curve is based on the assembly 1m cable with 2 connectors on each end.